

ulaz Ø160

izlaz Ø160

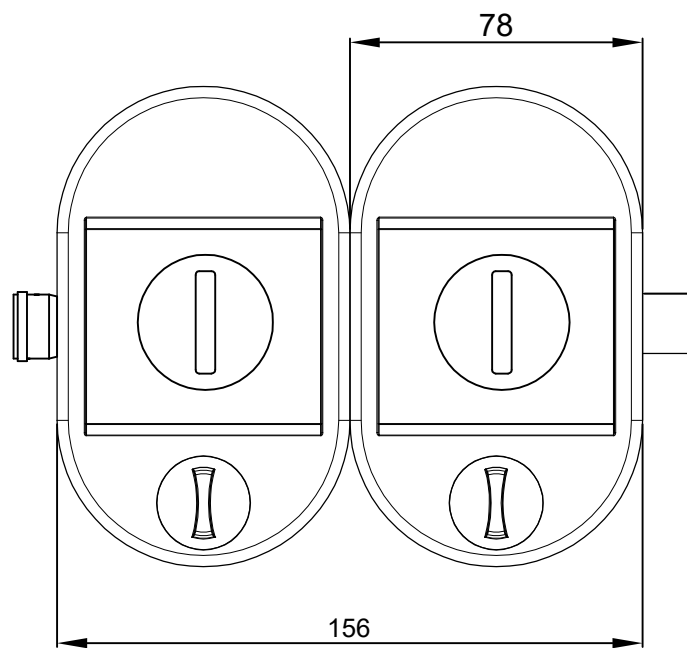
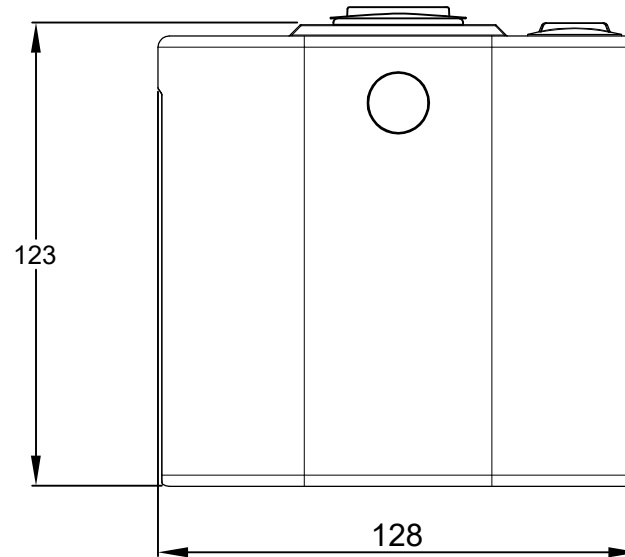
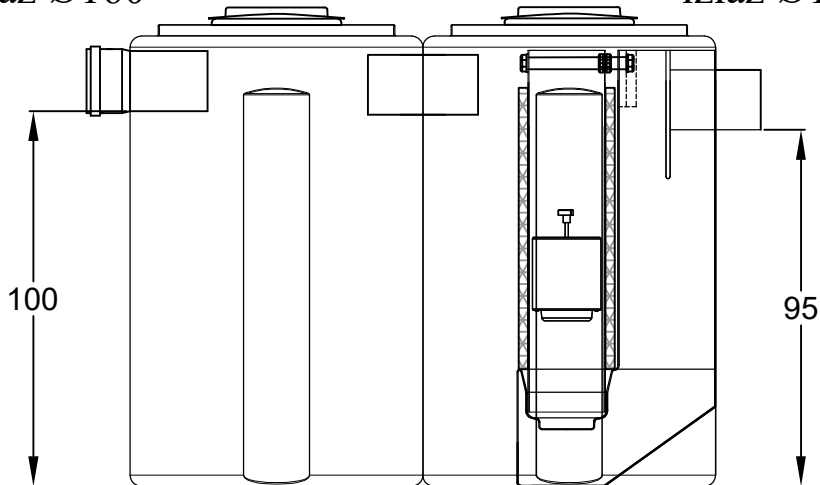

napomena:

Separator lakih tekućina (naftnih derivata)
za parkirališne površine model DUALBLOCK



Aquos Eco d.o.o.

www.aquoseco.hr

SEPARATOR LAKIH TEKUĆINA
DUALBLOCK tip AQ 2000 RB 2
Ø ul/izl 160

Projekt:	0724 A2KZT	Norma HR/EU:	HRN EN 858-1:2002 HRN EN 858-2:2003	Klasa:	klasa I	MDK:	< 5 mg/l
Datum:		Uredio:		Ukupno stranica:		Sjedeća stranica:	